

sunways

Grid-connected PV Inverter
Three Phase Six MPPT

User Manual

S T T - 5 0 K / 6 0 K T L

CONTENTS

1. Preface.....	5
1.1 Overview.....	5
1.2 Target Groups.....	5
2. Safety Instructions.....	5
2.1 Safety Notes.....	5
2.2 Statement.....	5
2.3 Important Safety Matters.....	6
2.4 Symbols Explanation.....	7
3. Product Introduction.....	9
3.1 Basic Features.....	9
3.2 Appearance Introduction.....	10
3.3 Display Interface.....	12
3.4 Packing List.....	13
4. Product Installation.....	13
4.1 Selection of Installation Location.....	13
4.2 Mounting the Inverter.....	15
4.3 Electrical Connection.....	17
4.4 Monitoring Device Installation.....	22
4.5 RS485 Communication Connection.....	22
5. Start and Stop.....	24
5.1 Inverter start-up.....	24
5.2 Inverter shutdown.....	24
6. General Operation.....	25
6.1 Display Operation.....	25
6.2 Auto-Test.....	26
7. Troubleshooting.....	27
7.1 Fault Messages.....	27
7.2 Maintenance.....	28
8. Technical Parameters.....	29

Attention

The products, services or features you purchase are subject to the commercial contracts and terms of Ningbo Sunways technologies Co., Ltd. All or part of the products, services or features described in this document may not be within your purchasing or using scope. Unless otherwise agreed in the contract, the Company shall not make any express or implied declaration or guarantee of the contents of this document.

Due to product version upgrades or other reasons, the contents of this document will be updated periodically. Unless otherwise agreed, this document serves only as a guide to use, and all statements, information and recommendations in this document do not constitute any express or implied guarantee.

Manufacturer: Ningbo Sunways technologies Co., Ltd.

Address: No. 1, Second Road, Green Industrial Zone, Chongshou Town,
Cixi City, ZheJiang Province, PEOPLE' S REPUBLIC OF CHINA

Website: www.sunways-tech.com

Service Mail: service@sunways-tech.com

Hotline: +86 400-9922-958

1.Preface

1.1 Overview

This manual is an integral part of Sunways STT50~60kW series three-phase inverters (hereinafter referred to as the inverters). It mainly introduces the assembly, installation, electrical connection, debugging, maintenance and troubleshooting of the products. Before installing and using inverters, please read this manual carefully, understand the safety information and be familiar with the functions and characteristics of inverters.

1.2 Target Groups

This manual is applicable to the electrical installers with professional qualifications and the people who bought this inverter. If there are any problems in the installation process, please call Sunways service telephone at [+86 400-9922-958](tel:+864009922958) or email Sunways at service@sunways-tech.com for consultation.

2.Safety Instructions

2.1 Safety Notes

2.1.1 Before installation, you should read this manual carefully and follow the instructions in this manual strictly.

2.1.2 Installation operators need to undergo professional training or obtain electrical related professional qualification certificates.

2.1.3 When installing, do not touch any part of the inner part of the inverter except the terminals.

2.1.4 All electrical installations must conform to local electrical safety standards.

2.1.5 If the inverter needs maintenance, please contact the local designated personnel for system installation and maintenance.

2.1.6 To use this grid-connected inverter for power generation needs the permission of the local power supply authority.

2.1.7 During the operation of the inverter, the surface temperature may be higher and there is a risk of burns. Do not touch.

2.1.8 When installing photovoltaic panels in the daytime, the photovoltaic panels should be covered with opaque materials to avoid the risks and danger of high voltage at the panel end in sunlight.

2.2 Statement

Ningbo Sunways technologies Co., Ltd. has the right not to undertake quality assurance in any of the following circumstances:

2.2.1 Damages caused by irregular transportation.

2.2.2 Damages caused by incorrect storage, installation or use.

2.2.3 Damages caused by installation and use of equipment by non-professionals or untrained personnel.

2.2.4 Damages caused by failure to comply with the instructions and safety warnings in the products and documents.

2.2.5 Damages caused by running in an environment that doesn't meet the requirements which stated in the documents.

2.2.6 Damages caused by operation beyond the parameters specified in applicable technical specifications.

2.2.7 Damages caused by unauthorized disassembly, alteration of products or modification of software codes.





2.2.8 Damages caused by abnormal natural environment (force majeure, such as lightning, earthquake, fire, storm, etc.).

2.2.9 Any damages caused by the process of installation and operation which unable to follow the local standards and regulations.

2.2.10 Products beyond the warranty period.

2.3 Important Safety Matters



The following symbols may appear in this manual, which represent the following meanings:

Symbol	Description
 Danger	Used to warn of urgent dangerous situations, if not avoided, it could result in death or serious personal injury.
 Warning	Used to warn of potentially dangerous situations, if not avoided, it may result in death or serious personal injury.
 Caution	Used to warn of potentially dangerous situations, if not avoided, it may result in moderate or minor personal injury.
 Attention	Used to transmit the safety warning information about equipment or environment, if not avoided, it may cause equipment damage, data loss, equipment performance degradation or other unpredictable results. "Attention" does not involve personal injury.
 Note	Used to highlight important information, best practices and tips, etc.









2.4 Symbols Explanation

This chapter mainly elaborates the symbols displayed on the inverter, nameplate and packing box.





2.4.1 Symbols on the Inverter

Symbol	Description
	A fault occurred if the red light is on, please report it to the installer or manufacturer as soon as possible.
	Inverter running indicator.
	Grounding symbol, the inverter casing needs to be properly grounded.

2.4.2 Symbol on the Inverter nameplate

Symbol	Description
	The inverter cannot be disposed of with household waste.
	Please read the instructions carefully before installation.
	Do not touch any internal parts of the inverter until 5 min after being disconnected from the mains and PV input.
	CE mark, the inverter complies with the requirements of the applicable CE guidelines.
	TUV certification.
	Danger. Risk of electric shock!
	The surface is hot during operation and no touch is allowed.
	Electric shock hazard, it is strictly forbidden to use the person to disassemble the inverter casing.

2.4.3 Symbol on the Packing box

Symbol	Description
	Handle with care.
	This side up.
	Keep dry.
	Stacked layers.

3. Product Introduction

3.1 Basic Features

3.1.1 Function

The Sunways STT 50~60kW series is a three-phase grid-connected PV inverter which is used to efficiently convert the DC power generated by the PV string into AC power and feed it into the grid.

3.1.2 The STT 50~60kW series inverter contain 2 models which are list below: STT-50KTL, STT-60KTL.

3.1.3 Applicable grid type

The applicable grid types for the Sunways STT50~60kW series are TN-S, TN-C, TN-C-S, IT and TT. When applied to the TT grid, the voltage of N to PE should be less than 30V. See Figure 3-1 for details:

3.1.4 Storage conditions

- 1) Inverter must be stored in its original packaging.
- 2) The storage temperature should be in the range of -30°C and $+60^{\circ}\text{C}$, and the relative humidity stored is less than 90%.
- 3) If a batch of inverters needs to be stored, the height of each pile should be no more than 2 levels.

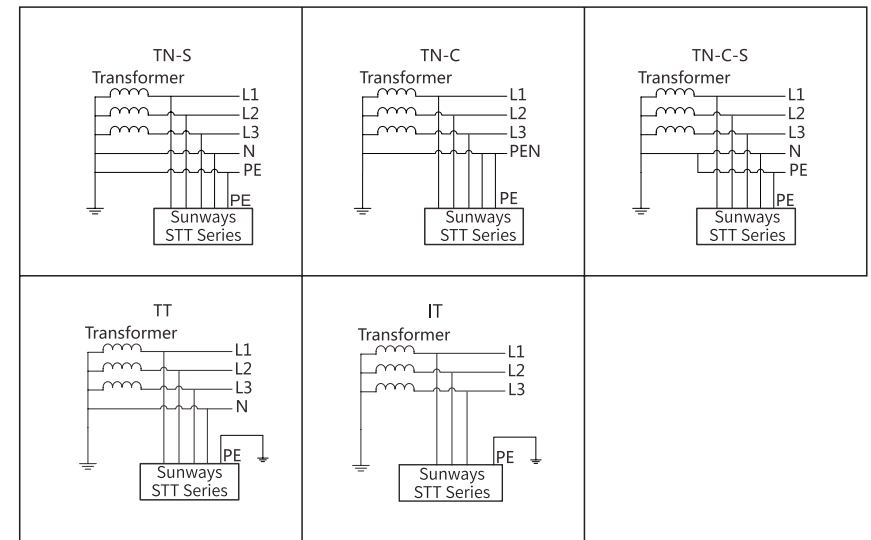

Figure 3-1 Applicable grid type

3.2 Appearance Introduction

3.2.1 Inverter front view, as shown in Figure 3- 2:

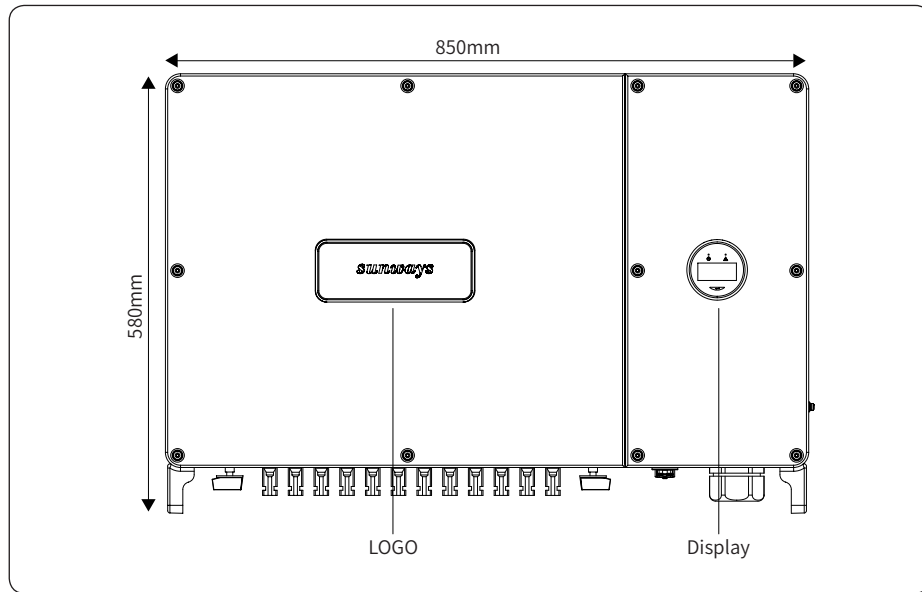

Figure 3- 2 Front view

3.2.2 Inverter side view, as shown in Figure3-3:

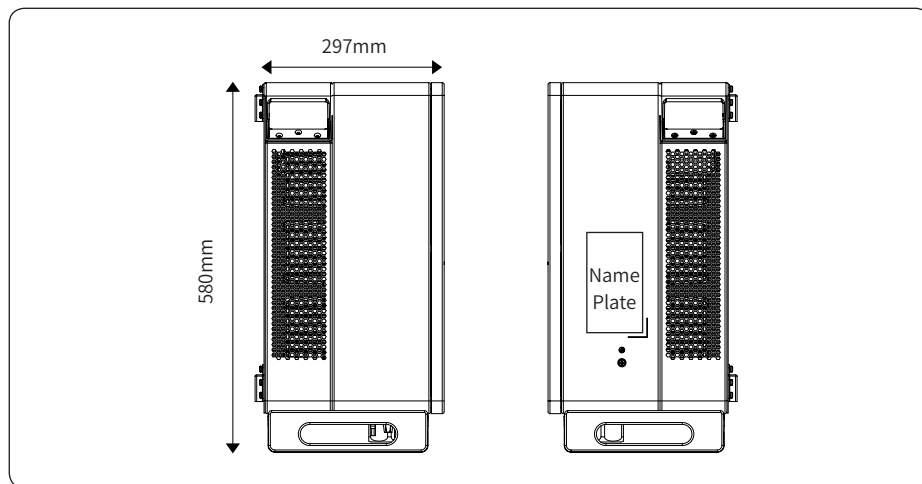

Figure 3- 3 Side view

3.2.3 Inverter bottom view, as shown in Figure 3- 4:

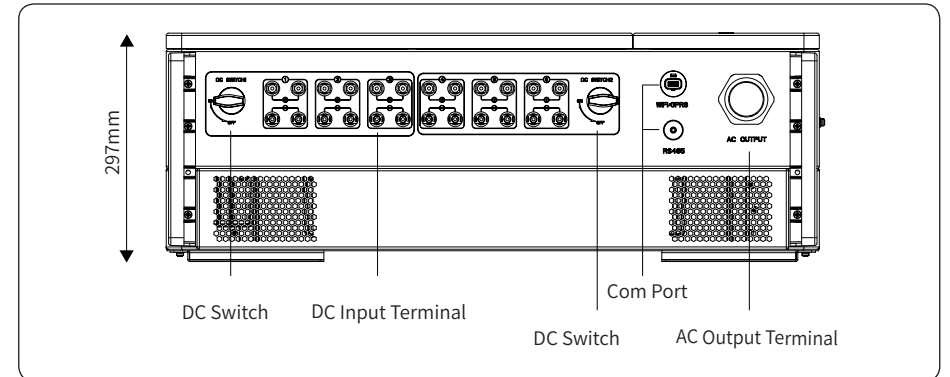

Figure 3-4 Bottom view

3.2.4 Inverter back view, as shown in Figure 3- 5:

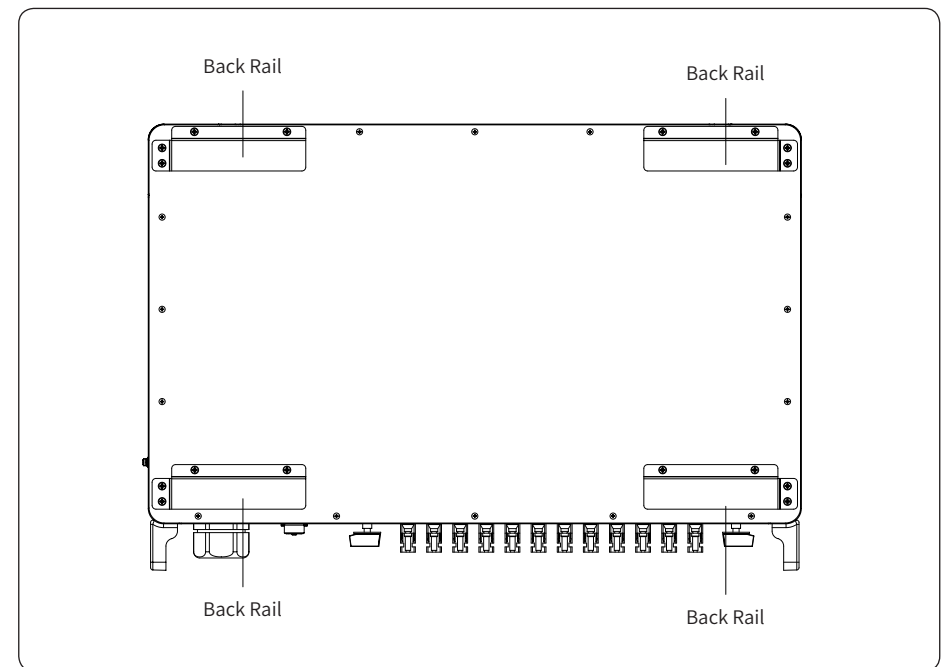

Figure 3-5 Inverter back

3.3 Display Interface

3.3.1 Display interface, as shown in Figure 3- 6



Figure 3-6 Display interface

Item	Indicator	Status	Description
1	Power Indicator	Off	No input voltage detected or input voltage is too low.
		Slow flashing	Inverter powered on, waiting for the grid connection.
		Quick flashing	Inverter detected grid power and entered self-test status.
		Always on	Normal, grid-connected and power generated.
2	Alarm Indicator	Always on	An alarm or fault is detected, and the display can view the specific fault information.
		Off	The inverter is running normally.
		Slow flashing	The monitoring device is not connected to the router or is not connected to the base station.
		Quick flashing	The monitoring device is connected to the router or connected to the base station but not connected to the server.
3	OLED Display	On	Display the inverter operating information.
		Off	If the button pressed without any response, the screen is faulty or not well connected.
4	Button	Physical button	Switch OLED display information and set parameters by short press and long press.

3.4 Packing list

The packaging of the inverter includes the following accessories. Please check whether the accessories in the packing box are complete at the first time when receiving the goods. See Figure 3-7 for the packing list:

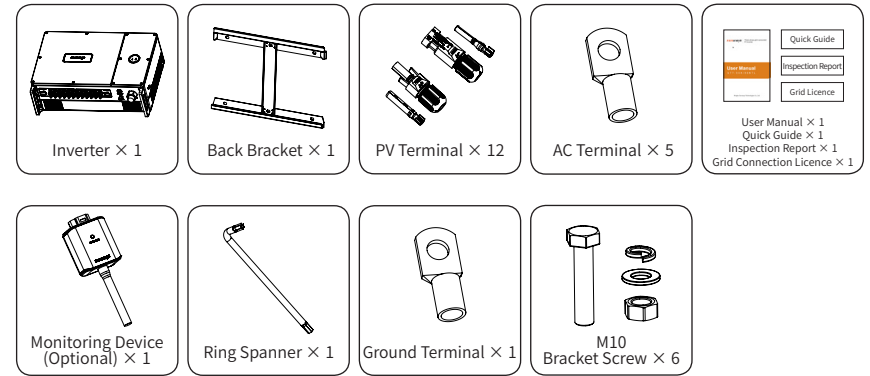

Figure 3- 7 Packing list

4. Product Installation

4.1 Selection of Installation Location

The Sunways STT 50~60kW series is designed with IP65 protection for indoor and outdoor installations. When selecting an inverter installation location, the following factors should be considered:

- 1) The object used for mounting the inverter must be strong and can withstand the weight of the inverter for a long time.
- 2) The inverter needs to be installed in a well-ventilated environment.
- 3) Do not expose the inverter directly to strong sunlight to prevent the power derating due to excessive temperature.
- 4) The inverter should be installed in a place with shelter to prevent direct exposure to sunlight and rain.
- 5) Install the inverter at the eye level for easy inspection of screen data and further maintenance.
- 6) The ambient temperature of the inverter installation location should be between -30 ° C and 60 ° C.
- 7) The surface temperature of the inverter can reach up to 75 ° C. To avoid risk of burns, do not touch the inverter while it's operating and inverter must be installed out of reaching of children.

4.1.1 Recommended installation location of the inverter, as shown in Figure 4-1:



Figure 4-1 Recommended installation location

	<p>Warning Do not put flammable and explosive articles around the inverter.</p>
---	--

4.1.2 The requirements for inverter installation spacing are shown in Figure 4-2:

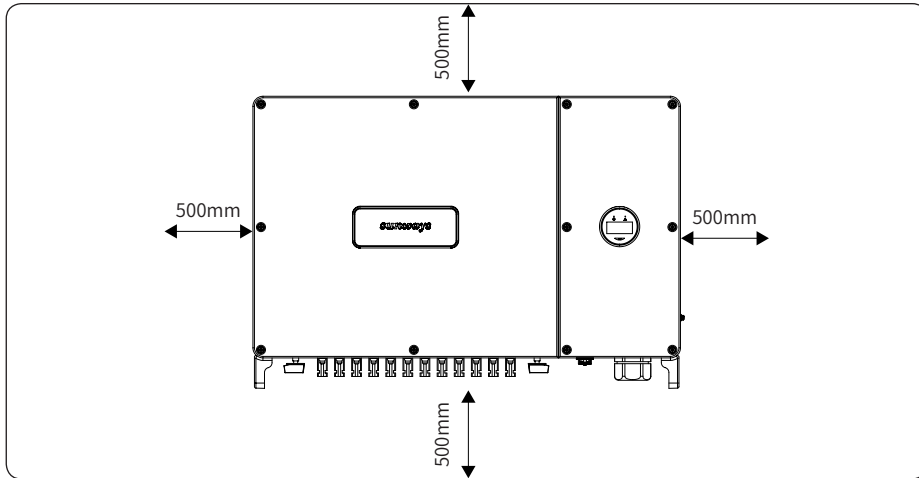

Figure 4-2 Recommended installation space

4.1.3 The installation angle of the inverter is recommended as shown in Figure 4-3:

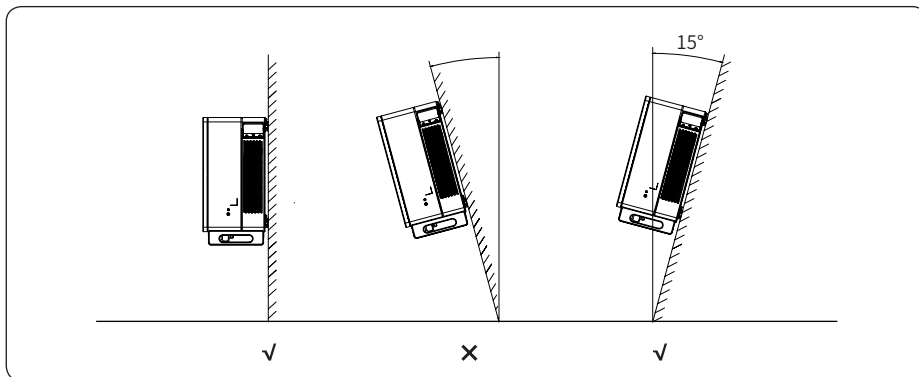

Figure 4-3 Recommended installation angle

4.2 Mounting the Inverter

4.2.1 Wall bracket installation

Dimensions of wall bracket, see Figure 4-4:

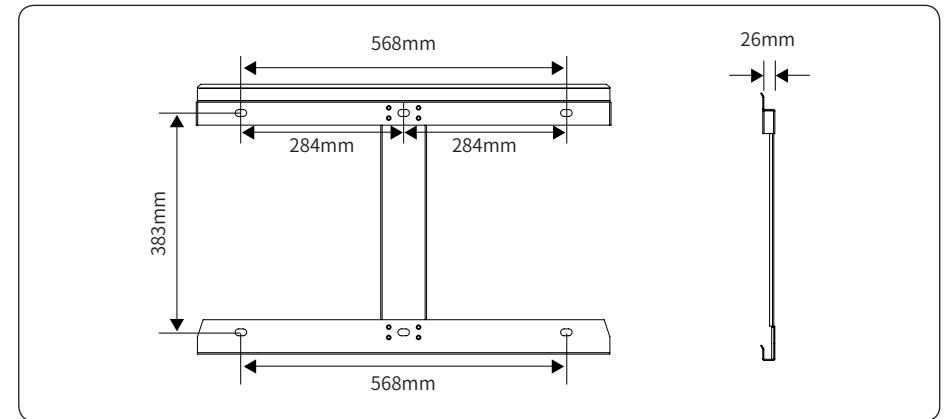

Figure 4-4 Dimensions of wall bracket

- 1) Use the inverter back bracket as the template to mark the position of 6 holes on installation bracket.
- 2) Use an electrical driller with 12mm diameter bit to drill 6 holes on the installation bracket. See Figure 4-5 for details:

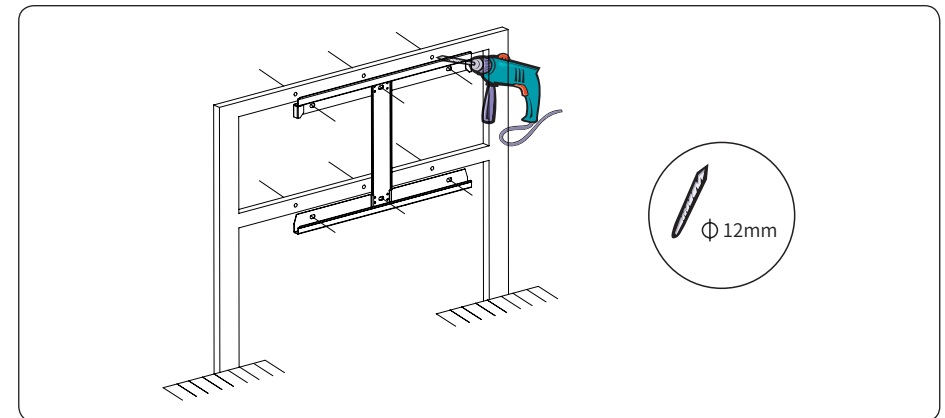

Figure 4-5 Mark the hole position

3) Follow the instructions in the picture below to install the M10 assembling bolts (bolt, spring washer, flat washer) and tighten the bolts with torque wrench in the torque of 35-40N.m, see Figure 4-6 for details:

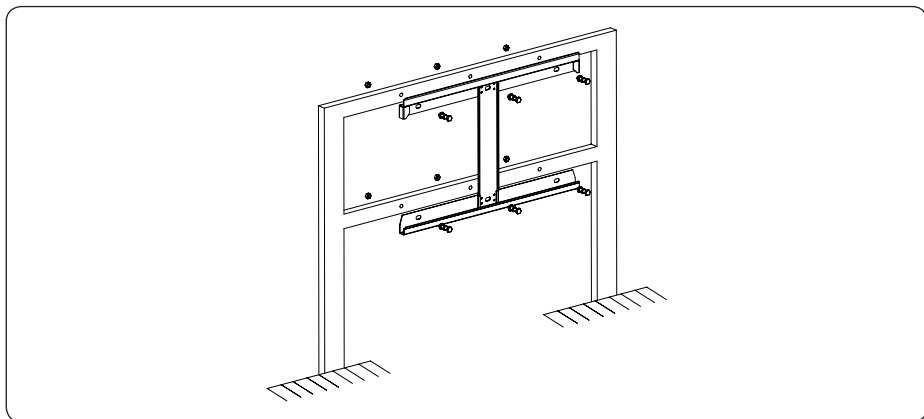

Figure 4-6 Fix the wall bracket

4) Lift up the inverter with both hands, hang the back rail on the fixed back bracket carefully, see Figure 4-7 for details:

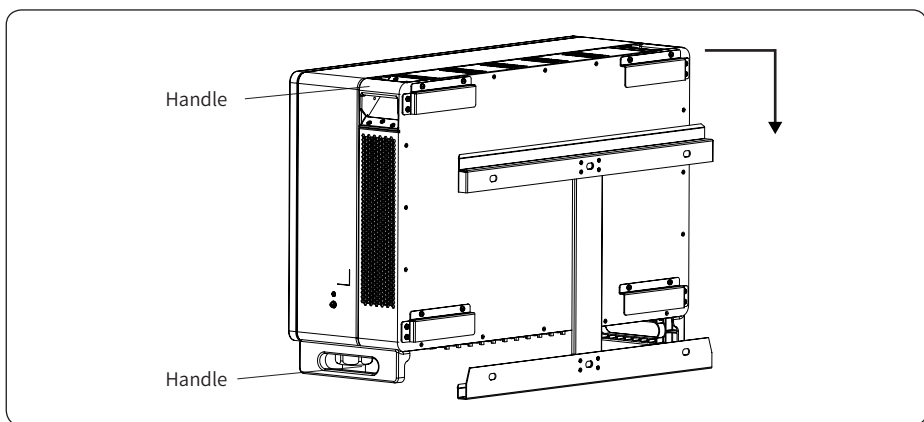







Figure 4-7 Mounting the inverter

4.3 Electrical Connection

Danger hint

 Danger	A high voltage in the conductive part of the inverter may cause an electric shock. When performing any installation on the inverter, make sure that the AC and DC sides of the inverter are completely de-energized.
 Warning	Do not ground the positive or negative pole of the PV string, otherwise it will cause serious damage to the inverter.
 Warning	Static may cause damage to the electronic components of the inverter. Anti-static measures should be taken during the repairing or installation.
 Attention	Do not use other brands or other types of PV terminals other than the PV terminal in the accessory package. Sunways has the right to refuse all damages caused by the mixed-use of terminals.
 Attention	Moisture and dust can damage the inverter, ensure the cable gland is securely tightened during installation. The warranty claim will be invalidated if the inverter damaged by the cable connector not well installed.

4.3.1 Inverter PV string connection

4.3.1.1 The following principles must be considered when making electrical connections to the inverter:

- 1) Disconnect the AC breaker on the grid side.
- 2) Two DC switches at the bottom of the inverter must be turned to the "OFF" position.
- 3) The number and type of the PV modules connected in series in each string in a same MPPT must be same.
- 4) Make sure the maximum output voltage of each PV string does not exceed 1100V.

4.3.1.2 DC connector assembly procedure

- 1) Select the appropriate photovoltaic cable according to the table below:

Cable type	Conductor transverse area (mm ²)	
	Scope(mm ²)	Recommended value (mm ²)
General photovoltaic cable	2.5-4.0	4.0

- 2) Strip off the DC cable insulation sleeve for 7 mm, as shown in Figure 4-8:

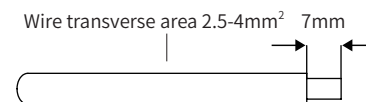

Figure 4-8

3) Disassemble the connector in the accessory bag, as shown in Figure 4-9:

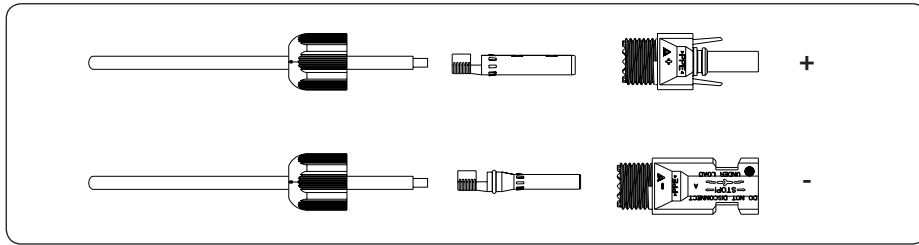

Figure 4-9

4) Insert the DC cable through the DC connector nut into the metal terminal and press the terminal with a professional crimping plier (pull back the cable with some power to check if it's tight enough), as shown in Figure 4-10:

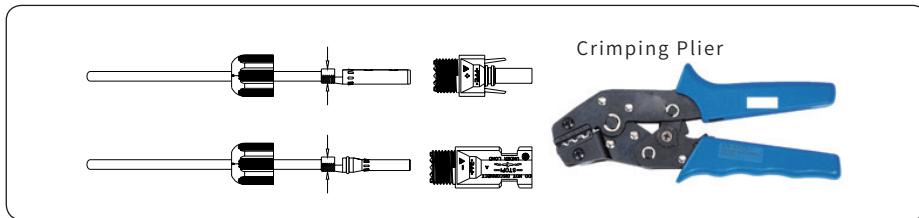

Figure 4-10

5) Insert the positive and negative cables into the corresponding positive and negative connectors and pull back the DC cable to ensure that the terminal is tightly attached in the connector.

6) Screw the nut to the end with some power and ensure the terminal is well sealed, as shown in Figure 4-11:

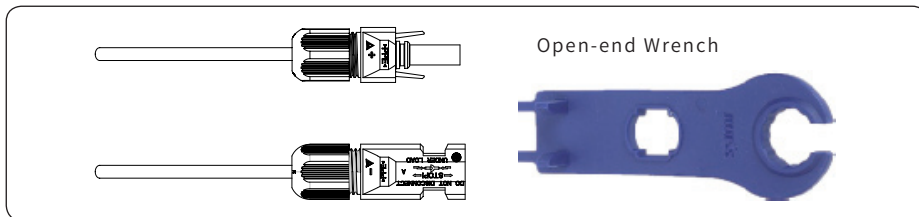

Figure 4-11



Warning

1. Before assembling the DC connector, make sure that the cable polarity is correct.
2. Use a multimeter to measure the voltage of the DC input string, verify the polarity of the DC input cable, and ensure that each string voltage is within 1100V.

7) Insert the positive and negative connectors into the inverter DC input terminals respectively, and a "click" sound represents the assembly in place, as shown in Figure 4-12:

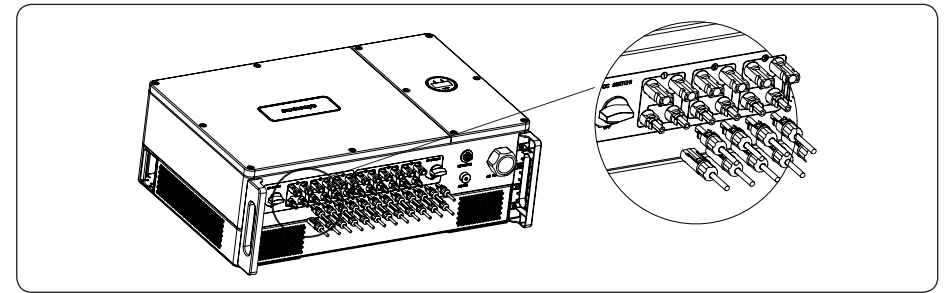

Figure 4-12

4.3.2 Connection of AC output

The Sunways STT 50~60kW series three-phase inverter applies to the three-phase power grid with a voltage of 380/400V and a frequency of 50/60Hz. The ceiling limit of AC output normal working voltage and frequency are 110% UN and 50.5Hz.

The recommended AC cable and breaker for the Sunways STT50~60kW series three phase inverter are shown in the following table:

Model	STT-50KTL	STT-60KTL
Cable	16mm ²	25mm ²
AC breaker	100A	125A



Warning

An AC breaker must be connected on the AC side of the inverter. Any loads cannot be directly connected to the inverter.

4.3.2.1 AC connector connection steps

1) According to the recommendations in above table to select an appropriate copper cable, strip the insulation sleeve of AC cable off for 150mm, and strip the end of 3L / PE / N wires for 8mm, then put the 5 AC terminals on the stripped metal cores respectively and tighten them with hydraulic clamp, as shown in Figure 4-13:

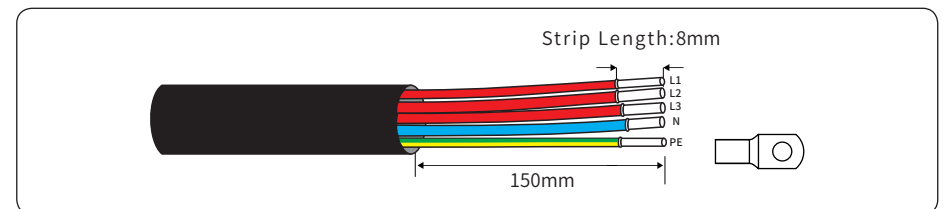

Figure 4-13

2) Take out the ring spanner from the accessory box and remove the right roof cover after unscrewed the screws on it, as shown in Figure 4-14:

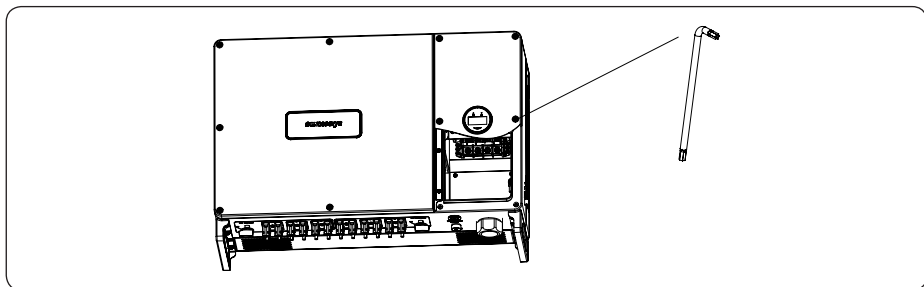

Figure 4-14

3) Put the AC cable through the cable gland and use a screwdriver to lock all five cables (L1/L1/L3/N/PE) to the correspondingly AC connector and pull back them with some power to make sure they're well connected. As shown in Figure 4-15:

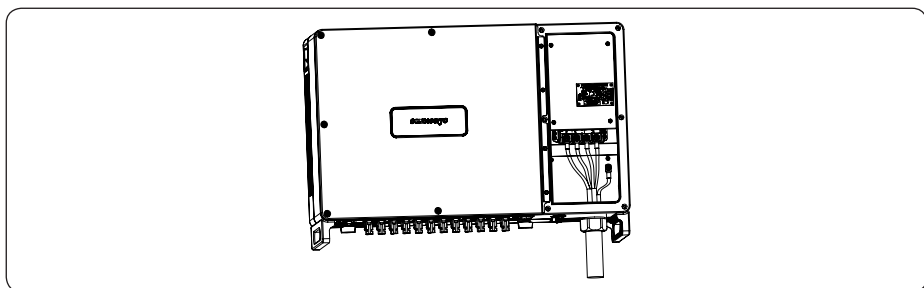

Figure 4-15

4) Insert the flat cable of the display to the connector in the ARM board, and place the top cover back and tighten it up.

5) Put back the right roof cover and lock with its original screws. As shown in Figure 4-16:

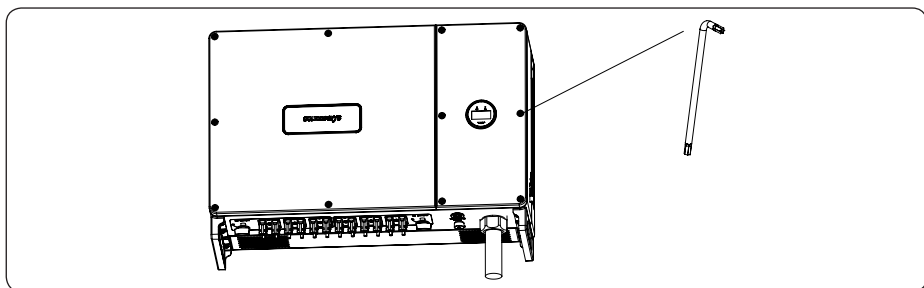





Figure 4-16

 <p>Attention</p>	<p>If there're more than one inverter in a project, do not open all inverters roof cover at the same time if you cannot finish the AC connection immediately. Any damages caused by the moisture and dust that came into the inverter on account of exposed to the air for a long time are out of Sunways warranty.</p>
--	---

4.3.3 External ground connection

 <p>Danger</p>	<p>Do not connect the N-wire as a protective ground wire to the inverter casing. Otherwise, it may cause electric shock.</p>
 <p>Attention</p>	<p>Good grounding is good for resisting surge voltage shock and improving EMI performance. Inverters must be well-grounded. For a system with only one inverter, just ground the PE cable. For a multi-inverter system, all inverters PE wire need to be connected to the same grounding copper bar to ensure equipotential bonding.</p>

Ground terminal connection steps:

- 1) The external grounding terminal is located in the lower right side of the inverter.
- 2) Fix the grounding terminal to the PE wire with a hydraulic clamp and lock the grounding terminal to the grounding hole in the inverter. As shown in Figure 4-17:
- 3) The transverse area of the external grounding is 16mm².

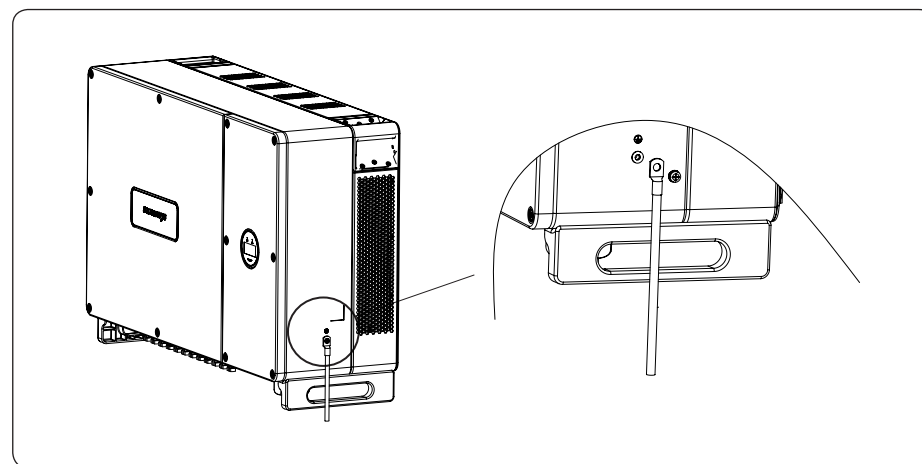

Figure 4-17 Grounding terminal connection

4.4 Monitoring Device Installation

Sunways STT 50~60kW series three-phase inverter supports WiFi, GPRS and RS485 communication, you can choose any of them according to your needs.

Plug the WiFi or GPRS module into the COM port in the bottom of inverter by following the direction that the side with indicator is up (as shown in Figure 4-18). A slight “click” sound during the installation represents that the assembly is in place.

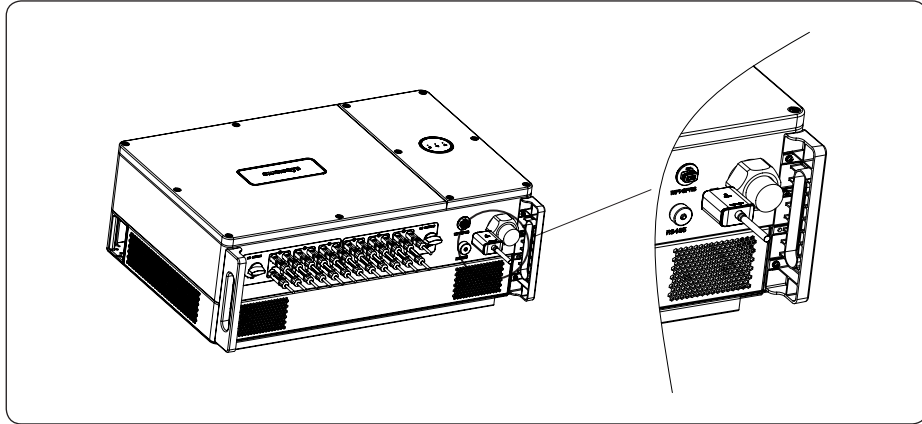



Figure 4-18 Monitoring device installation

 Note	<p>1.The GPRS version module does not need to be configured.</p> <p>2.The WiFi version module needs to be configured to the router for the first installation, and if the router name or password changed, you need to configure it again. For details, please refer to the [QUICK INSTALLATION GUIDE] which attached in the accessory bag.</p>
 Attention	<p>Don't touch the waterproof plug in the card slot unless replace the SIM card. If the SIM card needs to be replaced, please make sure the card slot is completely sealed by waterproof plug after replacing. Any damages caused by the waterproof plug sealing problem will be invalid of warranty.</p>

4.5 RS485 Communication Connection

STT 50~60kW series three-phase inverter supports multiple inverters connection to a data logger BlueLog in a daisy chain mode through RS485 protocol. Customers can check their inverters real-time power, warnings and status through the App “Linked Solar” or Sunways monitoring system (monitor.sunways-tech.com) anytime anywhere.

Multiple inverters connection diagram as shown in Figure 4-19:

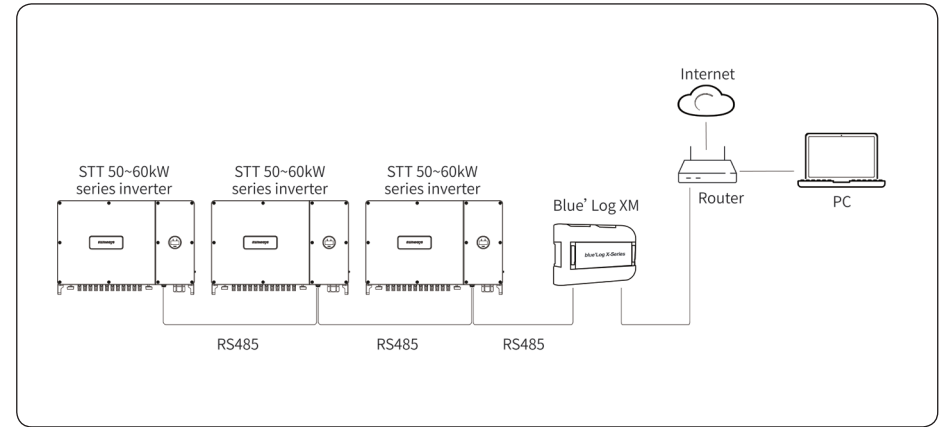

Figure 4-19 Multiple inverters connection diagram

The maximum distance between the inverter at the end of the daisy chain and the Blue'Log should be within 1000M.

4.5.1 RS485 Communication cable connection

Inverter RS485 communication port schematic diagram, as shown in Figure 4-20:

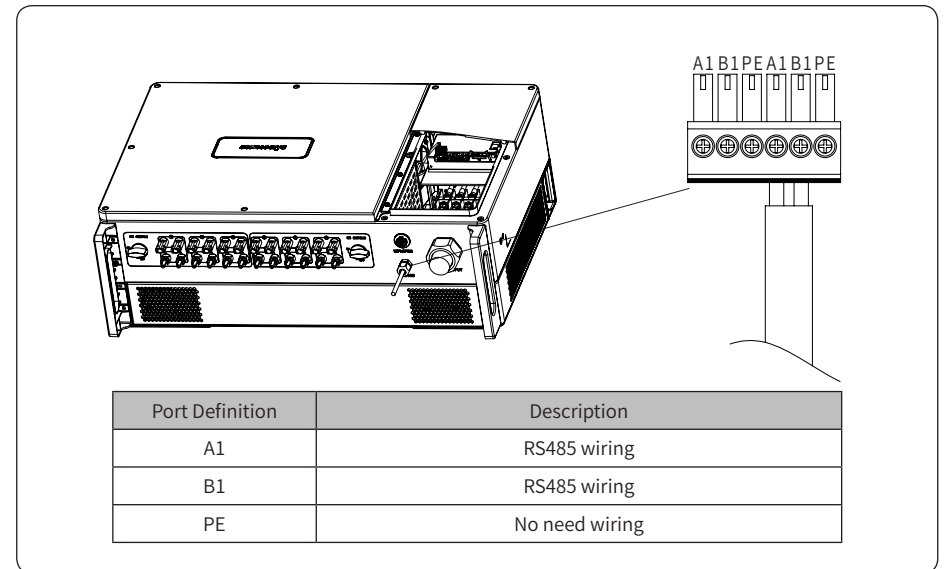



Figure 4-20 RS485 communication port schematic diagram

Suggest to use the communication cable with the transverse area of 0.2-1.5mm² and outer diameter of 5mm-10mm.

 Attention	RS485 cable requirements: Shielded twisted-pair cable or shielded twisted Ethernet cable.
---	---

5. Start and Stop

5.1 Inverter start-up

When starting the inverter, follow these steps:

- 1) Turn on the AC breaker first.
- 2) Turn on the two DC switches in the bottom. If the PV string voltage higher than the inverter start-up voltage, the inverter will start.
- 3) When both AC and DC power supply are normal, the inverter is ready to start. The inverter will initiate from checking its internal parameters and grid parameters, if it's within the range, the green light on the left side of the screen begins to flash, and the "Waiting" message will be displayed on the OLED display.
- 4) After 30 seconds, the inverter will start generating electricity, the green light will remain on, and the OLED display will display real-time power information.

5.2 Inverter shutdown

When turning off the inverter, please follow the steps below:

- 1) Turn off the AC breaker first.
- 2) Wait 30 seconds and then turn the two DC switches to the "OFF" position. At this time, there is remaining power in the inverter capacitor. Wait for 5 minutes until the inverter is completely de-energized before operating.
- 3) Disconnect the AC and DC cables.

6. General Operation

6.1 Display Operation

When the inverter is turned on, the following interfaces will be displayed on the OLED display, and you can check the information and modify the parameters of the inverter by short or long pressing the button. Please refer to the following display operation flow for details:

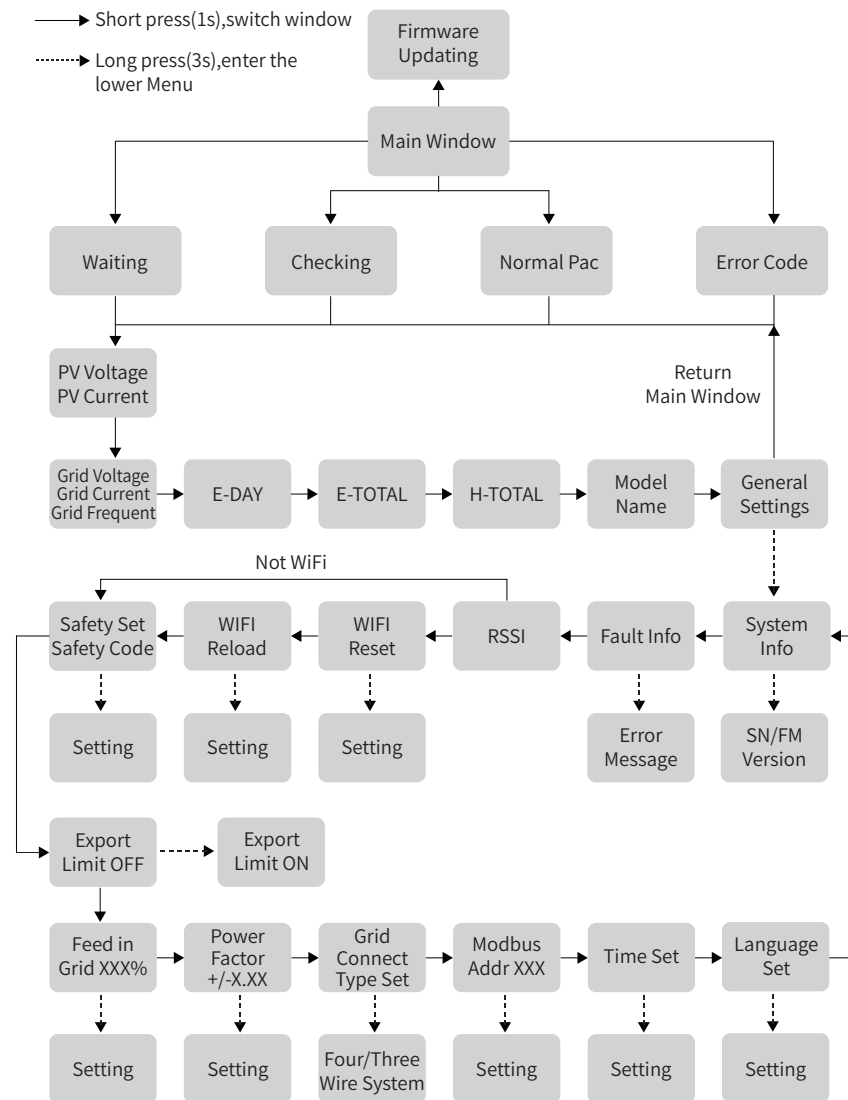

Tip: After every setting completed, wait for 10 seconds and the inverter will automatically save your settings or modifications.

6.2 Auto-Test

This function is disabled by default, and only will be functional in the safety code of Italy. Short press the button several times until “Auto Test CEI 0-21” displays on the screen, press and hold the button 3 seconds to activate “Auto Test”. After the auto test finished, short press the button several times until the screen displays “Auto Test Record”, and hold the button 3 seconds to check the test result.

The auto test type will be chosen from “Remote” and “Local” before starting the auto test. “Remote” is set as 1 by default, which only can be modified to “0” by sending an external command and “Local” is set as 0 by default, which can be modified to 1 through operating the button on the inverter. According to the requirements of the standard, the test has been divided into three modes:

- 1) “Remote” set as 1, “Local” set as 0, then the test order is 59.S1, 59.S2, 27.S1, 81>.S2, 81<.S2;
 - 2) “Remote” set as 1, “Local” set as 1, then the test order is 59.S1, 59.S2, 27.S1, 81>.S1, 81<.S1;
 - 3) “Remote” set as 0, “Local” set as 1, then the test order is 59.S1, 59.S2, 27.S1, 81>.S2, 81<.S2.
- Connect the AC cable, auto test will start after the inverter connected to the grid, see the operation steps below:

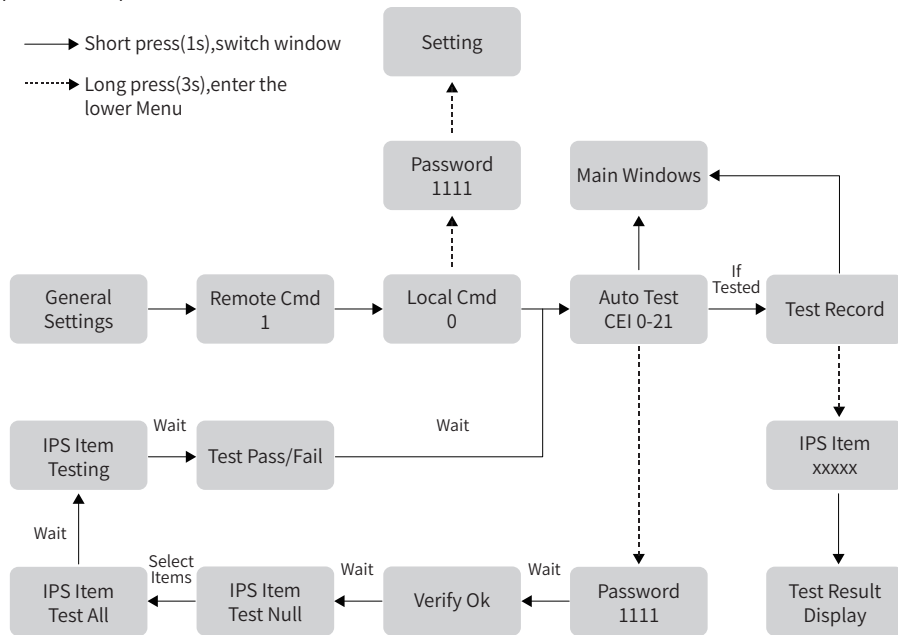

The auto test will start when the correct test item is selected, and the test result will be displayed on the screen when it finished. If the test success, it will display “Test Pass”, otherwise will display “Test Fail”. After each item tested, the inverter will reconnect to the grid and automatically start the next test item according to the requirements of CEI 0-21.

7.Troubleshooting





7.1 Fault Messages

Sunways STT50~60kW series three-phase inverter is designed in accordance with grid operation standard, and conform to the requirements of the safety and EMC. The inverter had passed a series of rigorous tests to ensure it runs sustainably and reliably before shipment. When a fault occurs, the corresponding fault messages will display on the OLED display, and in this case, the inverter might stop feeding into grid.

The fault messages and their corresponding troubleshooting methods are listed below:

Error Message	Solution
Mains Lost	1. Check whether the mains supply is lost. 2. Check whether the AC breaker and terminal are well connected.
Grid Voltage Fault	1. Check whether the impedance of the AC cable is too high to lead the grid voltage increased. Change a thicker AC cable if it is. 2. Extend the voltage protection range if it is allowed by the electricity company.
Grid Frequency Fault	1. Check whether the AC cable is correct and well connected. 2. Change to another country with wider protection range if it's allowed by the local electricity company.
DCI Fault	1. Restart the inverter. 2. Seek for help from the installer or manufacture.
ISO Over Limitation	1. Restart the inverter. 2. Seek for help from the installer or manufacture.
GFCI Fault	1. Restart the inverter. 2. Seek for help from the installer or manufacture.
PV Over Voltage	Reduce the number of PV panels to make sure the open-circuit voltage of each string is lower than the verter max allowed input voltage.
Bus Voltage Fault	1. Check whether the input voltage is over the limitation. 2. Seek for help from the installer or manufacture.
Inverter Over Temperature	1. Check whether the input voltage is over the limitation. 2. Seek for help from the installer or manufacture.
SCI Fault	1. Restart the inverter. 2. Seek for help from the installer or manufacture.
SPI Fault	1. Restart the inverter. 2. Seek for help from the installer or manufacture.
E2 Fault	1. Restart the inverter. 2. Seek for help from the installer or manufacture.
GFCI Device Fault	1. Restart the inverter. 2. Seek for help from the installer or manufacture.
AC Transducer Fault	1. Restart the inverter. 2. Seek for help from the installer or manufacture.
Relay Check Fail	1. Restart the inverter. 2. Seek for help from the installer or manufacture.
Flash Fault	1. Restart the inverter. 2. Seek for help from the installer or manufacture.

7.2 Maintenance

 Danger	<p>Risk of inverter damage or personal injury due to incorrect service! Always keep in mind that the inverter is powered by dual sources: PV strings and utility grid.</p> <p>Before any service work, observe the following procedure.</p> <ol style="list-style-type: none"> 1.Disconnect the AC circuit breaker and then set the DC load-break switch of the inverter to OFF; 2.Wait at least 5 minutes for inner capacitors to discharge completely; 3.Verify that there is no voltage or current before pulling any connector.
 Caution	<p>Keep non-related persons away! A temporary warning sign or barrier must be posted to keep non-related persons away while performing electrical connection and service work.</p>
 Attention	<p>Restart the inverter only after removing the fault that impairs safety performance.</p> <p>As the inverter contains no component parts that can be maintained, never arbitrarily replace any internal components.</p> <p>For any maintenance need, please contact SUNGROW. Otherwise, Sunways shall not be held liable for any damage caused.</p>
 Note	<p>Servicing of the device in accordance with the manual should never be undertaken in the absence of proper tools, test equipment or the latest revision of the manual which has been clearly and thoroughly understood.</p>

Items	Methods	Period
System clean	<p>Check the temperature and dust of the inverter.</p> <p>Clean the inverter enclosure if necessary.</p> <p>Check if the air inlet and outlet are normal.</p> <p>Clean the air inlet and outlet if necessary.</p>	Six months to a year (it depends on the dust contents in air.)

8. Technical Parameters

	Model	STT-50KTL	STT-60KTL
DC Input	Start-up Voltage (V)	200	200
	Max. DC Input Voltage (V)	1,100	1,100
	Min. DC Voltage (V)	180	180
	Rated DC Input Voltage (V)	620	620
	MPPT Voltage Range (V)	200~950	200~950
	Full Power MPPT Voltage Range (V)	390~850	470~850
	No. of MPP Trackers	6	
	No. of DC Inputs	12	
	Max. Input Current (A)	22/22/22/22/22/22	
	Max. Short-circuit Current (A)	30/30/30/30/30/30	
Backfeed current to the array (A)	0		
AC Output	Rated Output Power (KW)	50	60
	Max. Output Power (KW)	55	66
	AC output rated apparent power(KVA)	50	60
	Max. Apparent Power (KW)	55	66
	Rated Output Voltage (V)	3/N/PE, 230/400V	
	Rated AC Frequency (Hz)	50/60	
	AC output rated current (A)	72.5	87
	Max. Output Current (A)	83.6	95.3
	The measured Inrush current (A)	16.5A@10.6ms	17.1A@10.4ms
	Maximum output fault current (A)	180	180
	Maximum output overcurrent protection (A)	180	180
	Power Factor	0.8 leading ...0.8 lagging	
	Max. Total Harmonic Distortion	<3% @Rated Output Power	
DCI	<0.5%In		

	Model	STT-50KTL	STT-60KTL
Efficiency	Max. Efficiency	98.8%	98.8%
	European Efficiency	98.3%	98.3%
	MPPT Efficiency	99.9%	99.9%
Protection	DC Reverse Polarity Protection	Integrated	
	Insulation Resistance Protection	Integrated	
	DC Switch	Optional	
	Surge Protection	Integrated (Type II)	
	Over-temperature Protection	Integrated	
	Residual Current Protection	Integrated	
	Anti-islanding Protection	Frequency shift, Integrated	
	AC Short-circuit Protection	Integrated	
	AC Over-voltage Protection	Integrated	
General Data	Dimensions (mm)	850W*520H*290D	
	Weight (KG)	58	
	Protection Degree	IP65	
	Self-consumption at Night (W)	<1	
	Topology	Transformer-less	
	Operating Temperature Range (° C)	-30~60	
	Relative Humidity	0~100%	
	Operating Altitude (m)	3000	
	Cooling	Smart Fan Cooling	
	Noise Level (dB)	<55	
	Display	OLED & LED	
	Communication	RS485, WiFi/ GPRS/LAN(Optional)	
	Compliance	NB/T32004、IEC62109、IEC62116、VDE4105、VDE0126、AS4777、C10/11、CEI0-21、RD1699、NBR16149、IEC61727、IEC60068、IEC61683、EN50549、EN61000	



Address: No. 1, Second Road, Green Industrial Zone, Chongshou Town,
Cixi City, ZheJiang Province, PEOPLE'S REPUBLIC OF CHINA

Website: www.sunways-tech.com

Service Mail: service@sunways-tech.com

Hotline: +86 400-9922-958